



DX3 Anti-islanding Signal Generator

Driven by Energy.



DX3 Anti-islanding Signal Generator for DG

Operation and Installation Guide

General Description

The traditional electrical distribution networks facilitate the one-way flow of energy from the utility to the customer. The large-scale integration of distributed generators (DGs) is creating new concerns including the need to ensure that the DGs can detect islanding situations and disconnect themselves from the network in a safe & reliable manner. DX3 Anti-Islanding System provides a simple and effective solution in response to this challenge.



DX3 Anti-Islanding Signal Generator is installed at the distribution substation site. A step-down transformer, also called a Signal Transformer, transforms the primary voltage (at substation secondary site, for example, 25kV or 14.4kV) to a reduced level (for example, 600V) for the Signal Generator (SG) operation.

The Signal Generator creates the Anti-Islanding signal on the signal transformer secondary side. The signal transformer is optimally sized so that the Anti-Islanding signal does not interfere with the normal system operation, yet is capable of propagating to all the downstream feeders to be detected by the DX3 Anti-islanding Signal Detectors installed at DG sites. Should islanding occur, the Signal Detector trips the DG's immediately.

Features

- Simple to install at the substation.
- Uses a standard off-the-shelf utility transformer as the Signal Transformer.
- The Signal pattern is field adjustable.
- The signal strength is adjustable by changing the SCR firing angle.
- The Signal Generator can operate in three different modes (Master, slave, and standby). Multiple signal generators can be paralleled for increasing signal strength (Master and slave) or for redundancy (Master and standby).
- If the substation loses power, the signal generator also loses power and stops broadcasting. The downstream DX3 Anti-Islanding Signal Detectors (SDs) will not sense the signal, which automatically disconnects the DGs from the system.
- The Signal Generator can be re-energized by the utility within a specified auto-restart interval; the downstream Signal Detectors can be setup to automatically restart the DGs.
- Remote control functionality allows SCADA and EMS systems to turn off the signal generator remotely.

Operation

The control panel for the Signal Generator is shown in Fig. 1. There are 9 LEDs and 2 buttons. The main functions of the buttons and LEDs are described below.

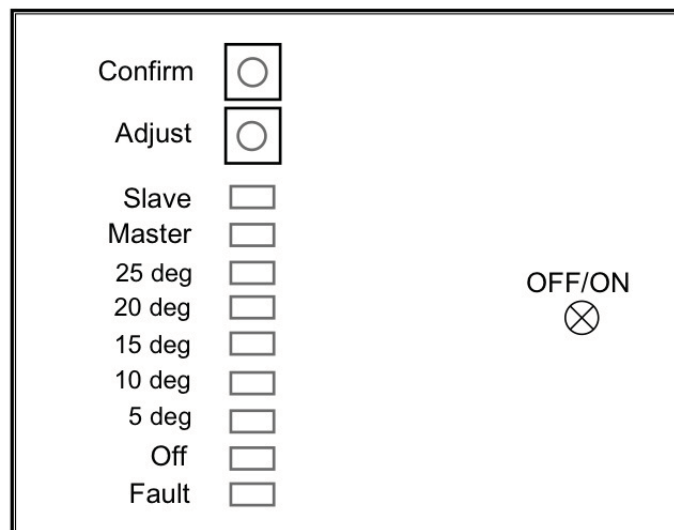

Fig. 1 Control Panel of the Signal Generator

Adjust button (B1) and Confirm button (B2)

Adjust button B1 is used to adjust the SCR firing angle and to change the SG unit operating mode (Master, Slave, or Standby). With each press, the LEDs corresponding to the next available status will flash.

The flashing LED indicates the last instruction has an unconfirmed status. To confirm the last instruction press *Confirm button B2*.

Fault LED (L1) and Off LED (L2)

Fault LED: Red LED indicates a fault on the Signal Generator.

Off LED: Red LED indicates a power off condition. It also indicates the SCR's firing angle is zero, i.e. no pulse is sent out.

Firing Angle LEDs (5 deg-L3, 10 deg-L4, ..., 25 deg-L7)

Yellow LEDs indicate the SCR firing angle. Values are 5 degree (L3), 10 degree (L4), 15 degree (L5), 20 degree (L6) or 25 degree (L7) ahead of the zero crossing point of the synchronization voltage. Press the "Adjust" button to choose the desired firing angle. When the LED corresponding to the desired firing angle is flashing, press the "Confirm" button to approve the input. Firing angles greater than 25 degrees are indicated by 2 LEDs. For 30 degrees, L7 and L3 are on; for 35 degrees L7 and L4 are on.

Master (L8) and Slave (L9)

Yellow *Master LED* (L8) on and *Slave LED* (L9) off indicate the SG unit is in Master mode. When two or more signal generators are connected in parallel, one signal generator should be set in Master mode, the others are in Slave or Standby mode. In Master mode, the SCRs are pulsed every 4 cycles.

Yellow *Slave LED* (L9) on and *Master LED* (L8) off indicate the SG unit is in Slave mode. When the signal generator in Master mode is operating, the signal generator in Slave mode should be synchronized to the Master unit. If signal generator in Master mode shuts down, the signal generator in Slave mode will continue to operate unsynchronized. If the Master unit is turned back on, the Slave unit will resume synchronization.

Yellow *Master LED* (L8) on and Yellow *Slave LED* (L9) on indicate the SG unit is in Standby mode. When the SG unit in Master mode is operating, the SG unit in Standby mode does not operate. When the Master SG stops operating, the Standby SG begins to operate. When the Enabling input to either Master or Standby SG is removed, the Standby SG stops.

Switch OFF/ON

The two-position selector switch can turn on or off the Signal Generator manually. When the switch is at the ON position, the SG is running at an assigned status and operating mode (Master/Slave), and SCRs' firing angle can be adjusted using two buttons. When the switch is at the OFF position, the SG is not operating, and the flashing LEDs indicate the SG status before it is turned off.

The circuit that the switch closes can also be opened by means of a remote contact (i.e. main substation control system). The circuit that this switch interrupts is fully isolated and consists of a Synchronization Output and a Synchronization Input, as described in the CN1 Terminals.

CN1 Terminal Definition

The CN1 Terminals in the control board allow the SG to be operating in Master, Slave, or Standby mode and to be monitored / controlled by the main substation control system.

Terminal CN1-1 is always connected to Ground.

Synchronization Input CN1-2, CN1-3: Terminals 2 and 3 provide an optical isolated 5V-28V AC/DC input.

- When the Sync Input has no signal, the SG is always off.
- When the SG is operating in Master or Standby mode and the Sync Input senses a 5V to 28V DC level, the SG operates without synchronizing to any other SGs. If the SG is in Slave mode, a DC level at the Sync Input will turn off the unit.
- When the Sync Input senses a 50% duty cycle every 4 cycles, the SG behaves differently depending on the operating mode: In Master mode, the SG runs without synchronization; in Slave mode, the SG synchronizes to the Sync Input signal (i.e. Master and Slave pulse synchronously); In Standby mode, the SG stops (i.e. Master SG is Ok, and Standby SGs are not needed).

Synchronization Output CN1-3, CN1-4: Terminals 3 and 4 provide a galvanically isolated 10V nominal output that is controlled by the SG. Sync Output is Off whenever the SG is programmed Off or if there is a rotation fault. If the SG is programmed for a non-zero power level, and if it is operating normally, Sync Output pulses with a 50% duty cycle and at a frequency equal to the SG pulse rate (i.e. every 4 cycles). When the SG is programmed for a non-zero power level and faults (i.e. shorted/open SCR, missing phase, over temperature) and yet is being commanded to run, the sync output goes to a constant DC level.

Relay contacts *NC (CN1-5, CN1-6)*, and *NO (CN1-7, CN1-8)*: Relay is energized when the SCRs are firing normally. If a NC contact is wired in series to the *Sync Input CN1-2, CN1-3*, the SG will be disabled when the control relay is turned Off. Multiple Normally Open contacts would be used in a multiple SG scenario.

Fault Conditions

The circuitry in the SG detects a variety of possible faults and external wiring conditions as outlined below.

- Phase rotation: Before the SG is allowed to run, it must detect correct phase rotation. This requirement is a requisite to be able to run a second SG in Slave mode.
- SCR shorted / Missing phase: Since a shorted SCR causes the same condition as a blown fuse to one of the Potential Transformers (PT), either one turns off the SG. And if the SG is programmed for a non-zero power level, the Sync Output is switched to a DC level so that a downstream Standby SG can take over, or a downstream Slave SG can turn off.
- Open SCR: The SG detects an open SCR by looking at the instantaneous voltage just after the SCR fires. If an open SCR condition is detected, the Sync Output goes to a DC level.
- Over-temperature: The SG continuously measures the SCR's heat sink temperature. When the first over-temperature threshold is reached, the SG automatically reduces power in an effort to keep SG running. If the second threshold (which is higher than the first over-temperature threshold) is reached, then the SG shuts down and the Sync Output is changed to a DC level.
- System fault: The SG uses a small microprocessor with a variety of internal check mechanisms. If any of these trip, the SG will reset and shutdown. For most system faults, the Sync Output goes to a DC Level.

Different operation scenarios

The signal generator operating status is indicated by the LEDs. Different operation scenarios are summarized in Table 1.

Table 1 Summarization of different SG operating scenarios

L1 Fault	L2 Off	L3-7 Angles	L8 Master	L9 Slave	Description
Off	Off	Off	Off	Off	No power
Off	On	Off	-	-	Red LED L2 indicates that the SG is energized, without faults. The firing angle of the SCRs is 0 degree, i.e. no pulse is sent out.
Off	Off	On	On	Off	One (or two) of the LEDs L3-L7 are On and LED L8 is On: Indicate that the SG unit is in Master mode. The SCR's firing angle is shown by the LEDs L3-L7. The SCRs are firing every 4 cycles.
Off	Off	On	Off	On	One (or two) of the LEDs L3-L7 are On and LED L9 is On: Indicate that the SG is in Slave parallel mode. The unit is synchronized to the Master SG.
Off	Off	On	On	On	One (or two) of the L3-L7 are On and both L8 and L9 are On: Indicates a Standby mode. The SG will turn on immediately (fire every 4th cycle) if the master SG fails.
On	On	Off			L1 is On (Red) and L2 is On (Red): Indicate there is a fault in the signal generator due to wrong phase rotation. It cannot proceed until the phase rotation is corrected.
On	On	Flash			L1 is On, L2 is On and some LEDs of L3-L9 are flashing: Red LEDs indicate there is a fault in the signal generator and the signal generator is not operating. The flashing LED indicates the SG's operating status prior to the fault.
Flash	On	Off			L1 is flashing and L2 is On: Indicate an internal fault within the CPU or control circuitry.

Table 1 Summarization of different SG operating scenarios (Cont...)

L1 Fault	L2 Off	L3-7 Angles	L8 Master	L9 Slave	Description
On	Flash	Flash			L1 is On, L2 is flashing and some LEDs of L3-L9 are flashing: Indicates there is a fault in the SG due to high temperature. The flashing LED indicates the SG status prior to the fault. Press 'Confirm' button to clear the status.
On	Off	Flash			L1 is On and some LEDs of L3-L9 are flashing: Indicates high temperature automatic reduce power mode. LEDs L3-L7 show steady according to the reduced firing angle.
Flash	Flash	Flash			L1 and L2 are flashing, and some LEDs of L3-L9 are flashing: Indicates the system is unable to verify that all three SCRs are conducting. Flashing L3-L9 indicates the SG status prior to the fault. Press 'Confirm' button to clear the status.
Flash	Off	Flash			L1 is flashing, and some LEDs of L3-L9 are flashing: Indicates one or more phases are missing. The flashing L3-L9 indicates the SG status prior to the fault. Press 'Confirm' button to clear the status.

Installation Notes

The DX3 Anti-Islanding Signal Generator is connected the distribution substation secondary side via a Signal Transformer which steps down to the SG's operating voltage (600V). The size of Signal Transformer depends on the fault level of distribution substation and the required signal strength.

To size the Signal Transformer or to verify if the present transformer will work for increased signal strength, please contact DX3 Enterprises Ltd. When the signaling channel is phase-to-ground, the Signal Transformer should be Wye-Ground / Wye-Ground connected.

PT Connection

Three multi-tap Potential Transformers (PT1, PT2, and PT3) are used to provide the synchronized three-phase voltages as well as to supply power to the Control Board. The configuration of each PT is shown in Fig.2.

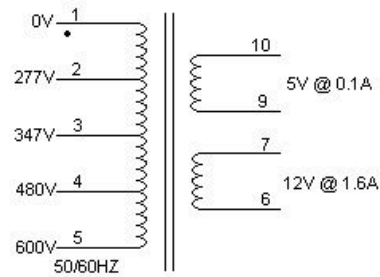

Fig.2 PT configuration

When installing the SG, appropriate taps should be selected for different signaling channel. For the phase-to-ground signaling in a 600V (phase-to-phase voltage) system, the PTs are Wye-connected, and the taps 1 and 3 (i.e. 347V) should be connected.

Interconnecting Synchronization Input and Synchronization Output

For single SG applications, a front panel On/Off switch connects CN1 Terminal 2 to 4 (Sync Input to Sync Output). A dry contact (i.e. a substation remote control relay contact) can be inserted in series with this switch. When the On/Off switch (or the dry contact) opens, the SG turns off.

For multiple SG configurations, the Sync Output of the master SG is daisy chained to the Sync Input of a Slave SG or Standby SG, as shown in Fig.3.

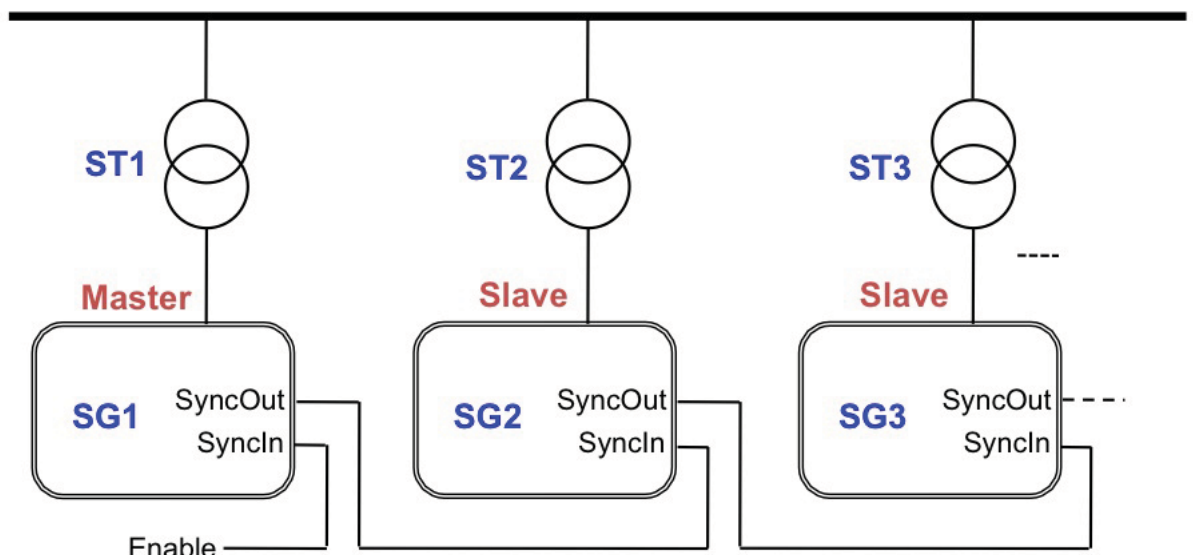

Fig.3 Multiple SGs scenario

Multiple remote control contacts would be wired in series with each Sync Input in addition to the local On/Off switch, i.e. for a Master/Slave setup, putting the Master's On/Off switch to off, would turn the Master SG off, which in turn puts a DC level on its Sync Output which can be sensed by the Slave SG and therefore it turns off as well.

For a Master/Standby setup the opposite thing occurs. Putting the Master's On/Off switch to off would turn off the Master SG, and turn the Sync Output into a DC level, which in turn would turn on the Slave unit.

In either setup, multiple remote control contacts are used to ensure that each Sync Input is removed when a shutdown is desired. Without a Sync Input signal all SG's regardless of their mode will turn off.

Moreover, relay contact NC (CN1-5, CN1-6) can be utilized to monitor the SG remotely. If the SG is operating normally, the relay contact NC (CN1-5, CN1-6) will be energized.

SPECIFICATIONS

Dimensions:	36"W x 39.8"H x 15.2"D
Shipping Weights:	272 lb
Nominal Voltage:	600V
Temperature:	-40°C to 75°C
Signal pattern:	Phase-to-ground signaling, 1 signal every 4 cycles

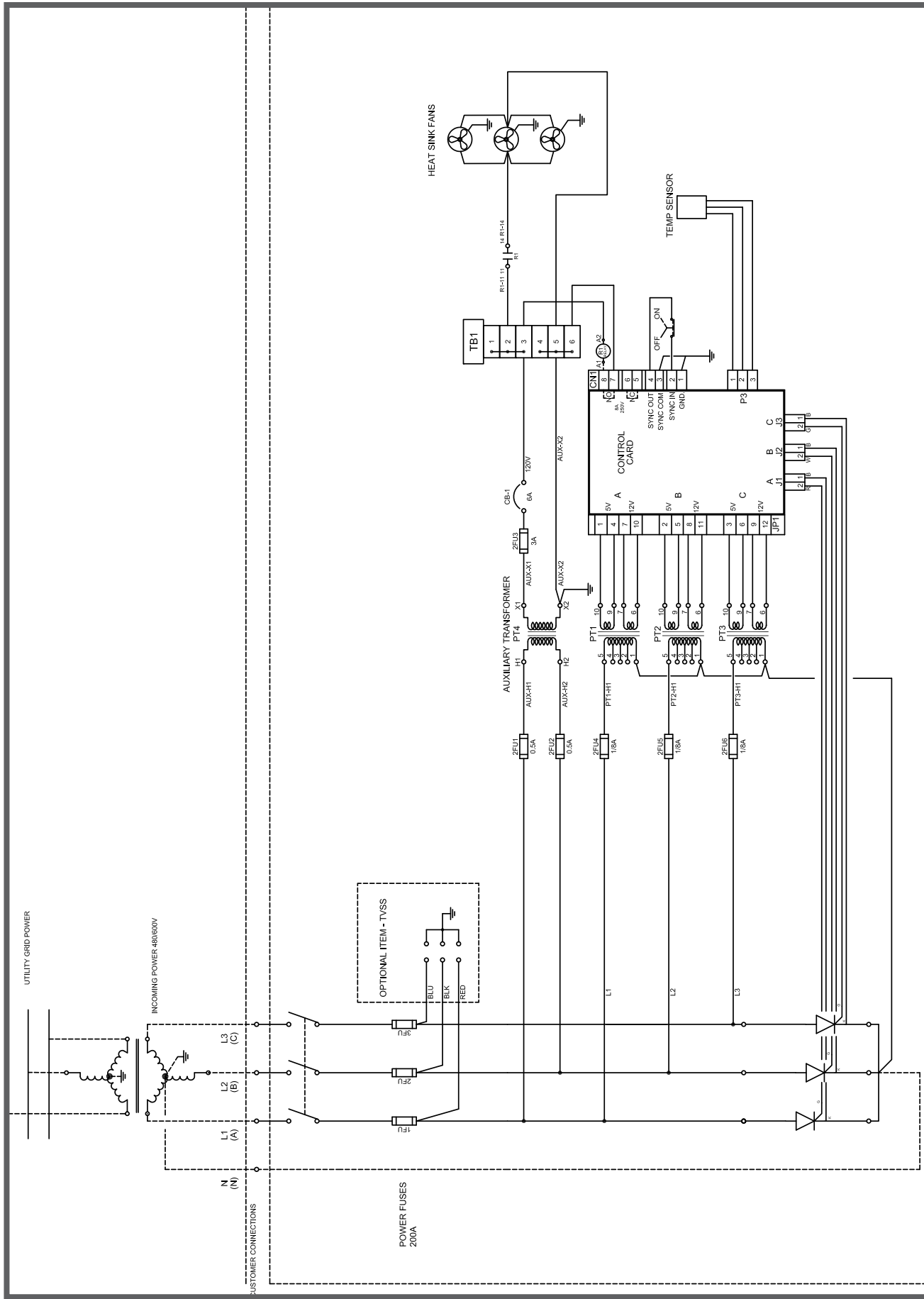

ANTI-ISLANDING SIGNAL GENERATOR WYE CONNECTION

For more information on these or other
products & services email us at:

sales@dx3ltd.com



Unit #109, 117 Pembina Road
Sherwood Park, AB,
T8H 0J4

(866) 796-0303 (Toll Free)
(780) 467-0303 (Office)
(866) 821-3732 (Toll Free Fax)